

IMPORTANT: The tank must be surrounded in concrete as per installation procedures. Refer to 'Installation Detail' sheet available from the Broadway Group.

DIMENSIONS ARE SUBJECT TO DIMENSIONAL TOLERANCES. If critical, check physically prior to installation. This drawing is confidential and must not be copied, reproduced or passed to a third party without written permission from Broadway.

Rev.	Amendment	By	Chk'd	Date
------	-----------	----	-------	------

Title **Vortech™ T1-120-1P-50FS pump station fitted with single pump (free standing), integral valves & DN50 pipework**

Client

The Broadway Group
136 Stanwell Road, Ashford, Middlesex
TW15 3QP. Telephone 0845 601 9006

Drawn G.J.
Checked T.E.
Date Oct. 2005
Scale 1:20

Internal reference
Drawing number 3148

Revision

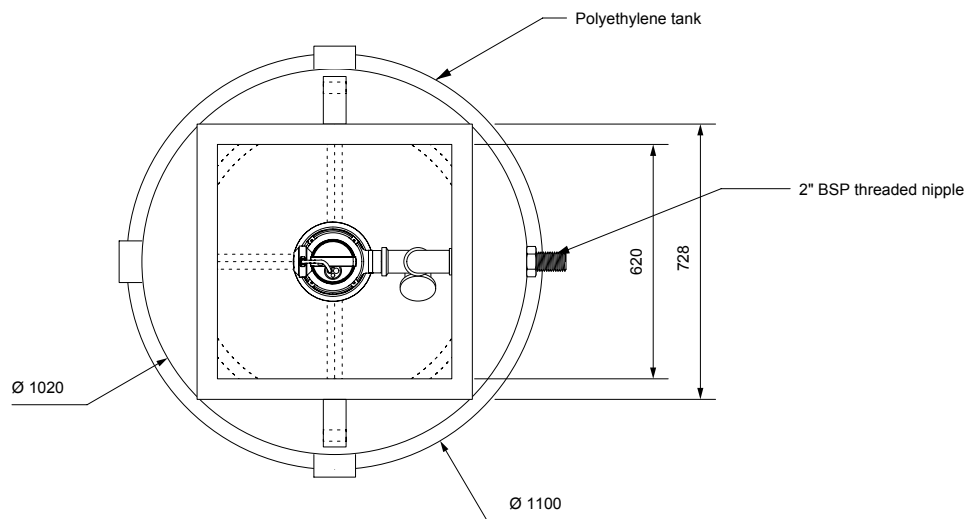

PLAN

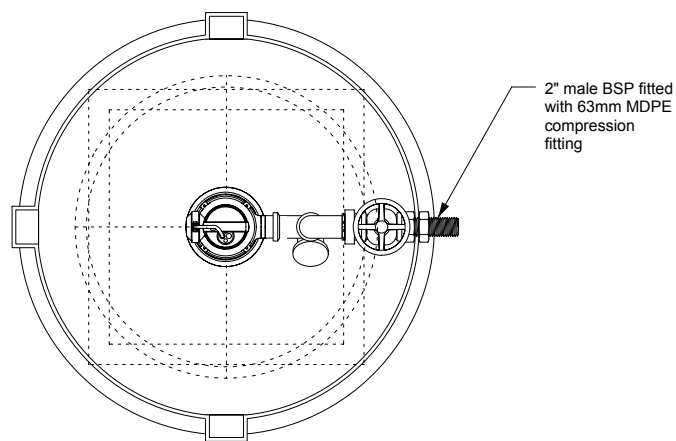

SECTIONAL PLAN

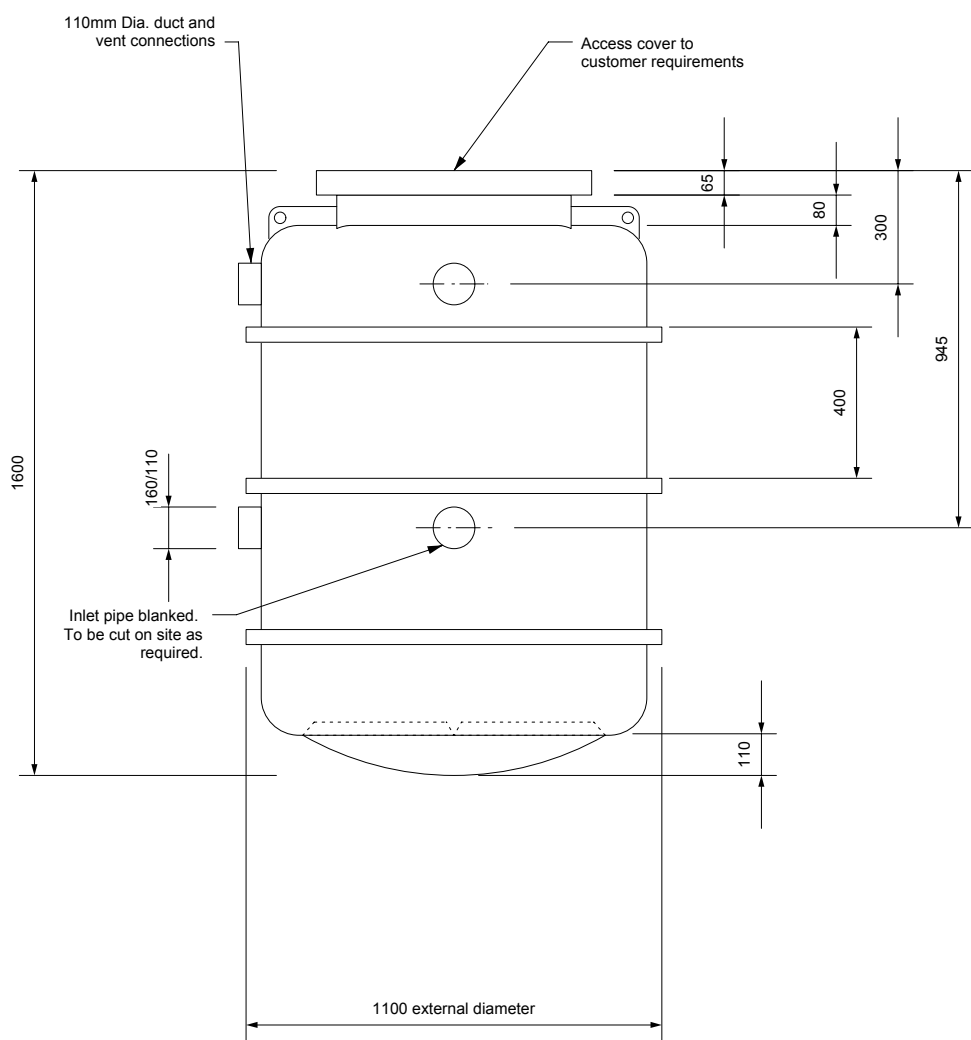

END ELEVATION

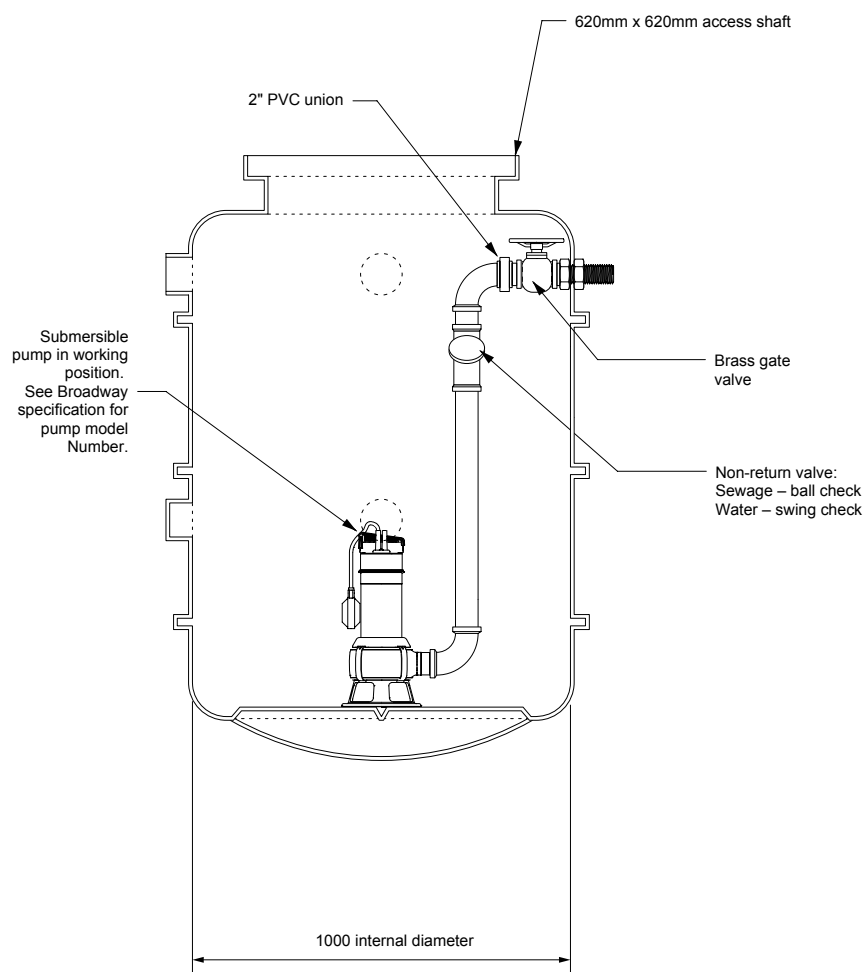

SECTIONAL ELEVATION

IMPORTANT: The tank must be surrounded in concrete as per installation procedures. Refer to 'Installation Detail' sheet available from the Broadway Group.

DIMENSIONS ARE SUBJECT TO DIMENSIONAL TOLERANCES. If critical, check physically prior to installation. This drawing is confidential and must not be copied, reproduced or passed to a third party without written permission from Broadway.

Rev.	Amendment	By	Chk'd	Date

Title **Vortech™ T1-160-1P-50FS pump station fitted with single pump (free standing), integral valves & DN50 pipework**

Client

The Broadway Group
136 Stanwell Road, Ashford, Middlesex
TW15 3QP. Telephone 0845 601 9006

Drawn **G.J.**
Checked **T.E.**
Date **Oct. 2005**
Scale **1:20**

Internal reference

Drawing number **3152**

Revision

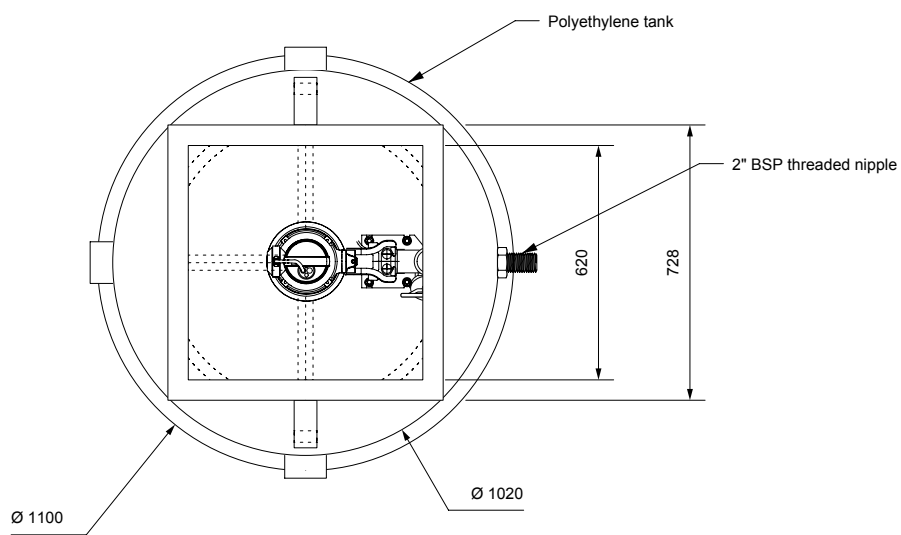

PLAN

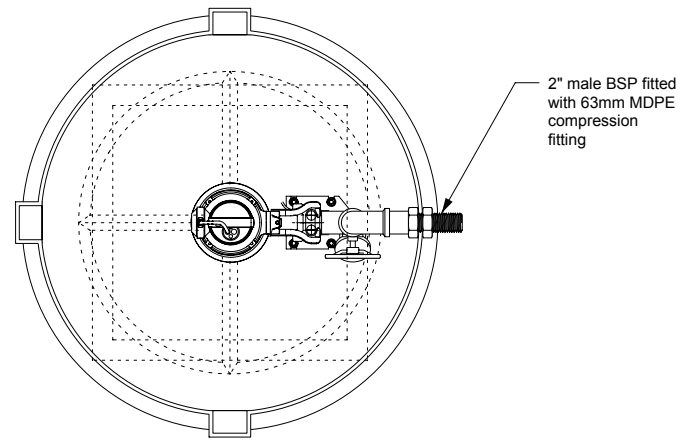

SECTIONAL PLAN

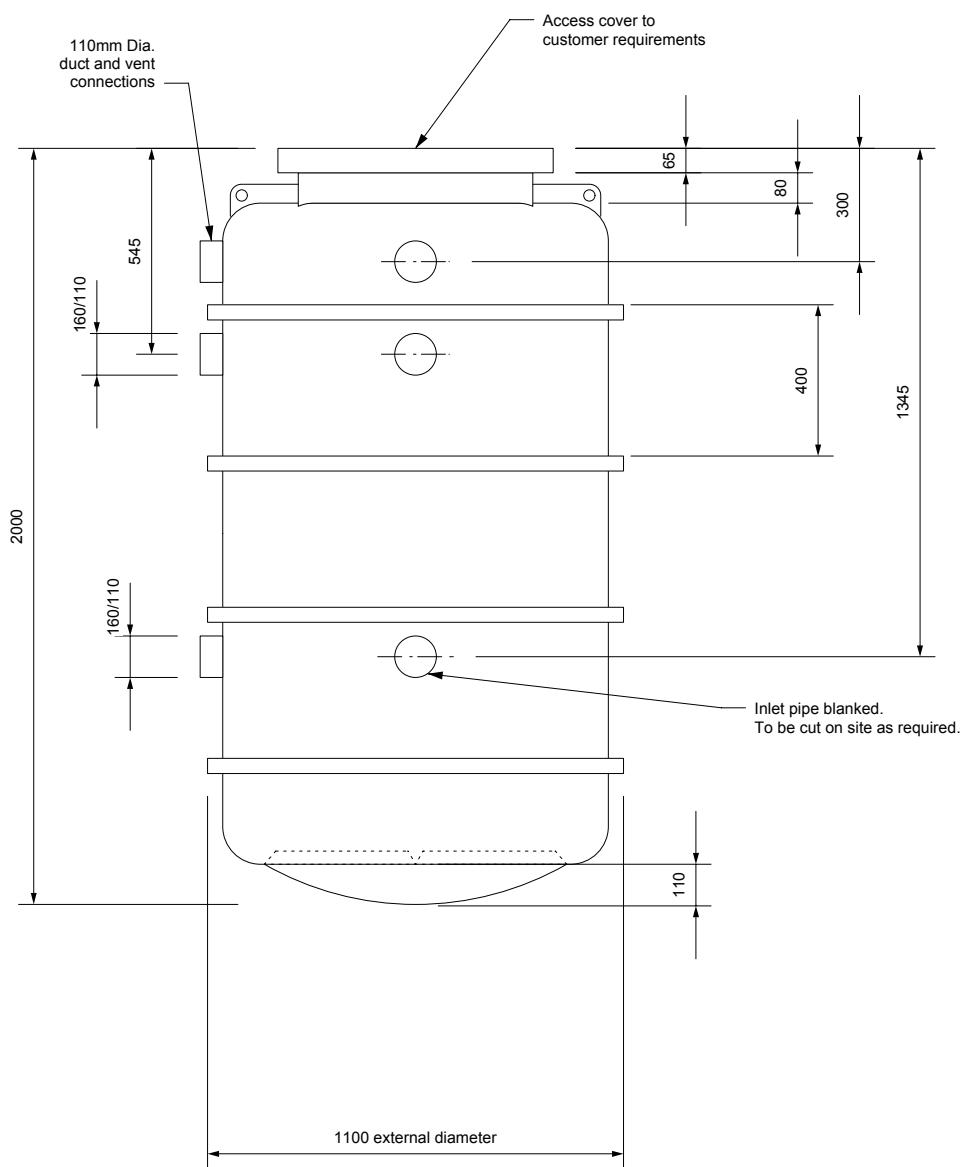

END ELEVATION

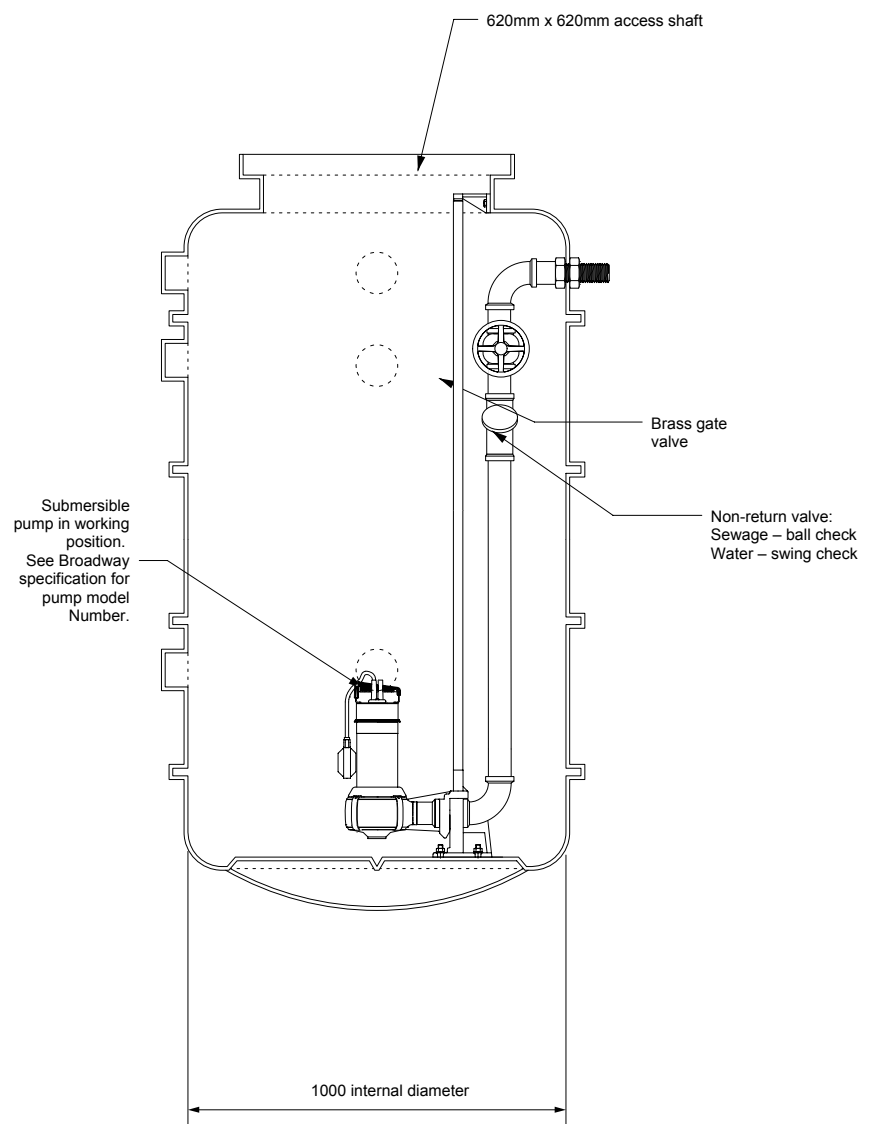

SECTIONAL ELEVATION

IMPORTANT: The tank must be surrounded in concrete as per installation procedures. Refer to 'Installation Detail' sheet available from the Broadway Group.

DIMENSIONS ARE SUBJECT TO DIMENSIONAL TOLERANCES. If critical, check physically prior to installation. This drawing is confidential and must not be copied, reproduced or passed to a third party without written permission from Broadway.

Rev.	Amendment	By	Chk'd	Date
------	-----------	----	-------	------

Title **Vortech™ T1-200-1P-50GR pump station fitted with single pump (guide rail mounted), integral valves & DN50 pipework**

Client

The Broadway Group
136 Stanwell Road, Ashford, Middlesex
TW15 3QP. Telephone 0845 601 9006

Drawn **G.J.**
Checked **T.E.**
Date **Oct. 2005**
Scale **1:20**

Internal reference
Drawing number **3157**
Revision

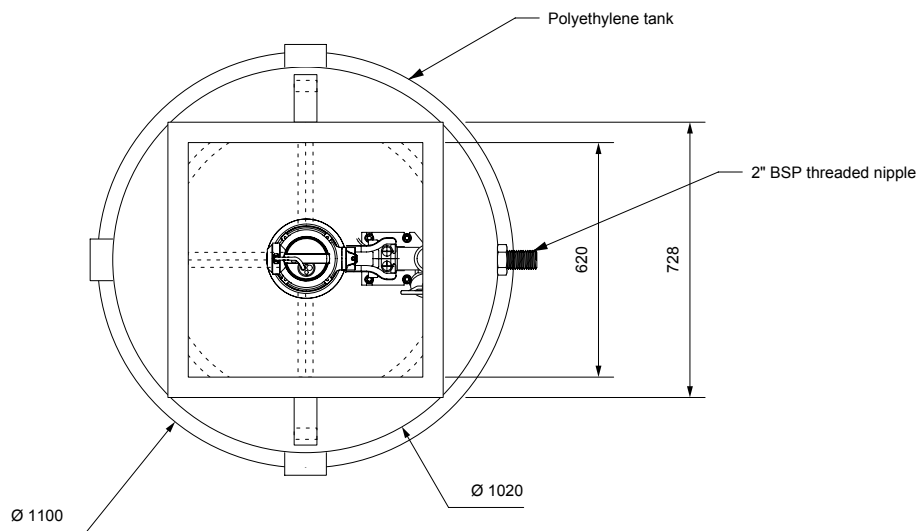

PLAN

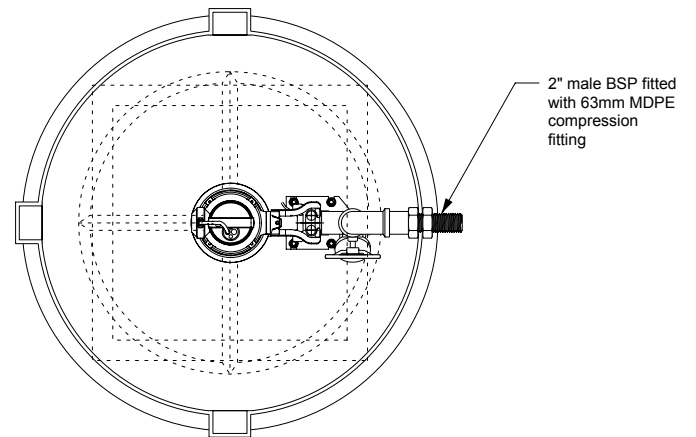

SECTIONAL PLAN

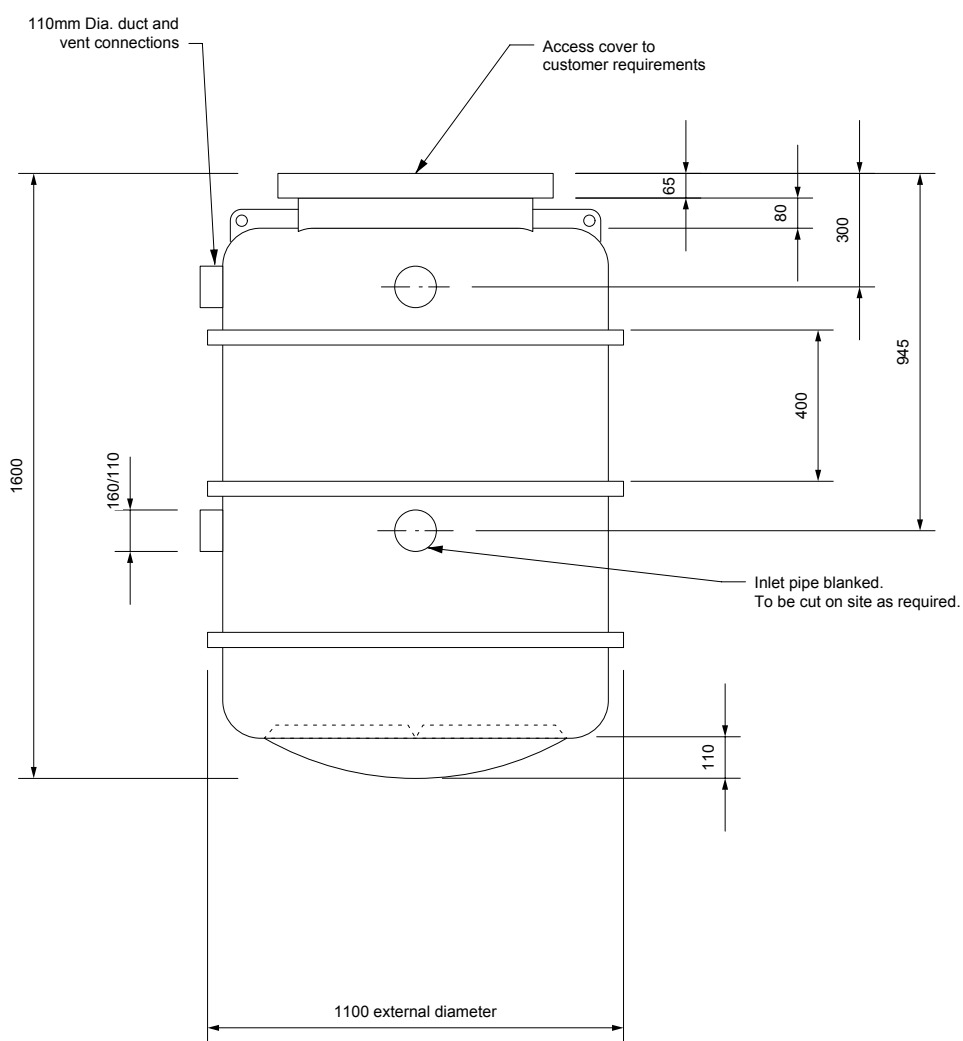

END ELEVATION

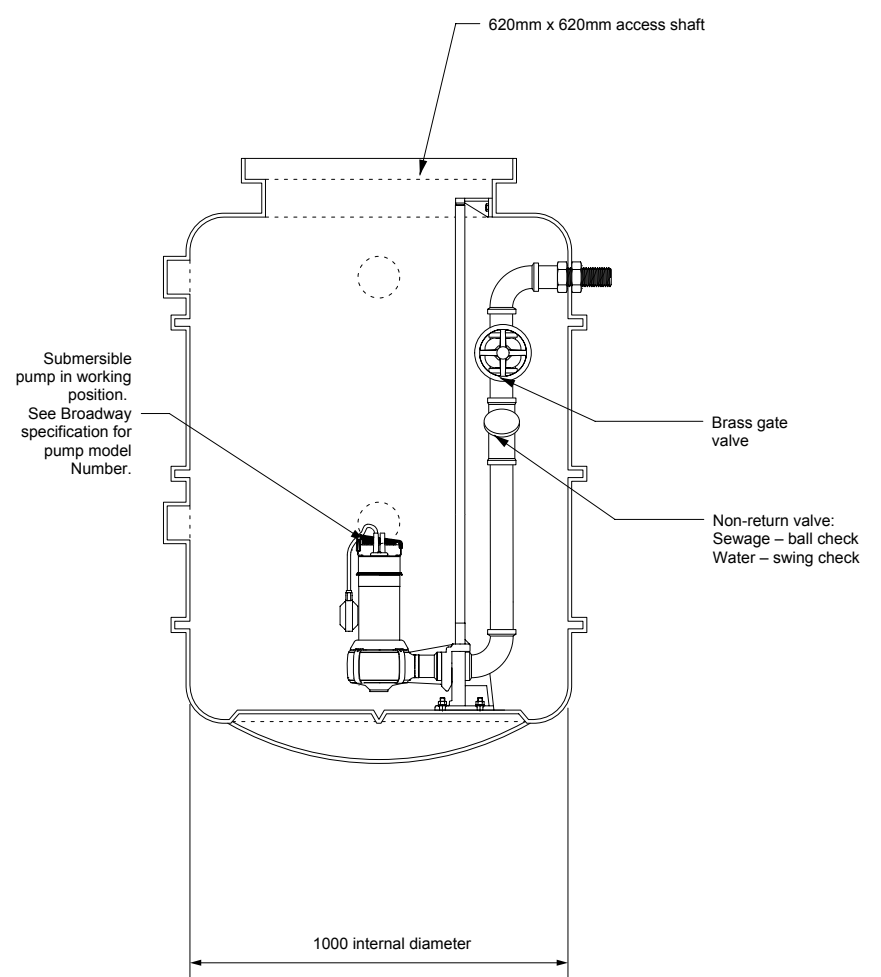

SECTIONAL ELEVATION

IMPORTANT: The tank must be surrounded in concrete as per installation procedures. Refer to 'Installation Detail' sheet available from the Broadway Group.

DIMENSIONS ARE SUBJECT TO DIMENSIONAL TOLERANCES. If critical, check physically prior to installation. This drawing is confidential and must not be copied, reproduced or passed to a third party without written permission from Broadway.

Rev.	Amendment	By	Chk'd	Date

Title **Vortech™ T1-160-1P-50GR pump station fitted with single pump (guide rail mounted), integral valves & DN50 pipework**

The Broadway Group

136 Stanwell Road, Ashford, Middlesex TW15 3QP. Telephone 0845 601 9006

Drawn **G.J.**
 Checked **T.E.**
 Date **Oct. 2005**
 Scale **1:20**

Internal reference

Drawing number **3153**

Revision

Client

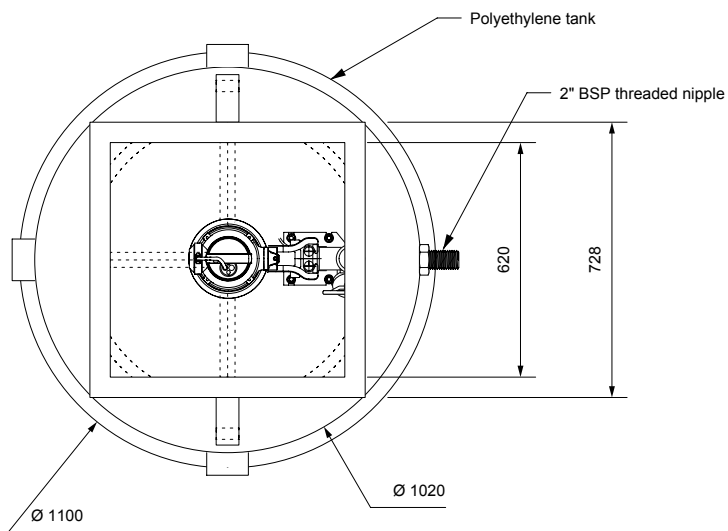

PLAN

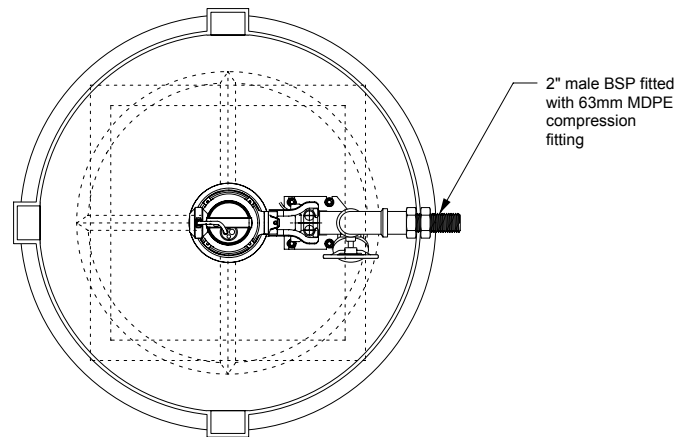

SECTIONAL PLAN

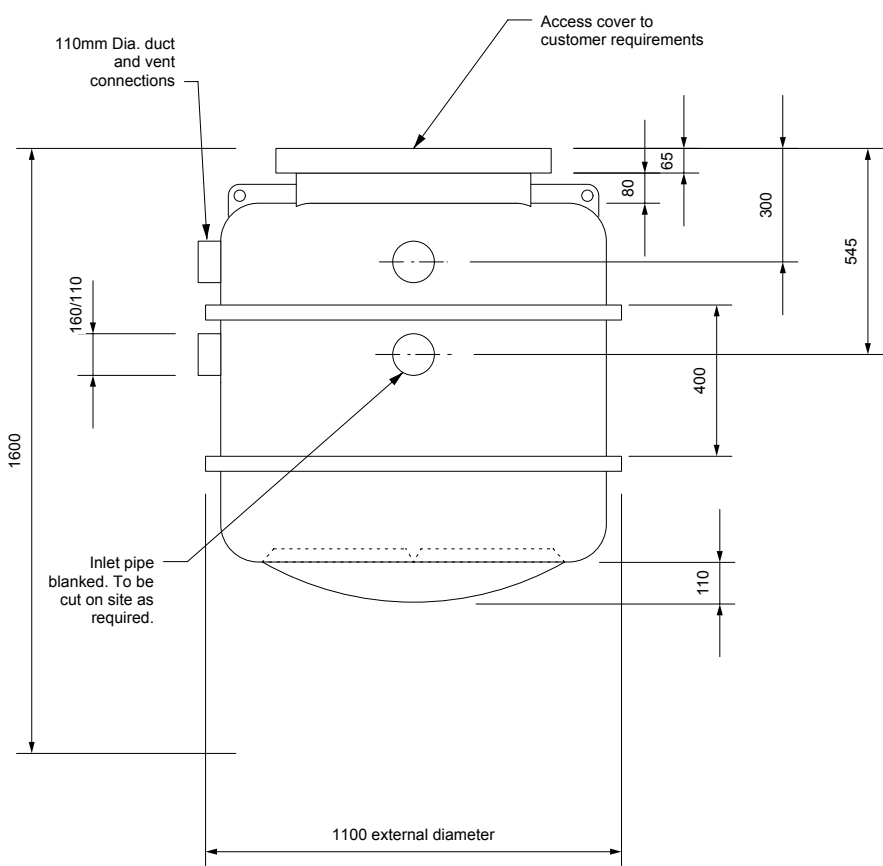

END ELEVATION

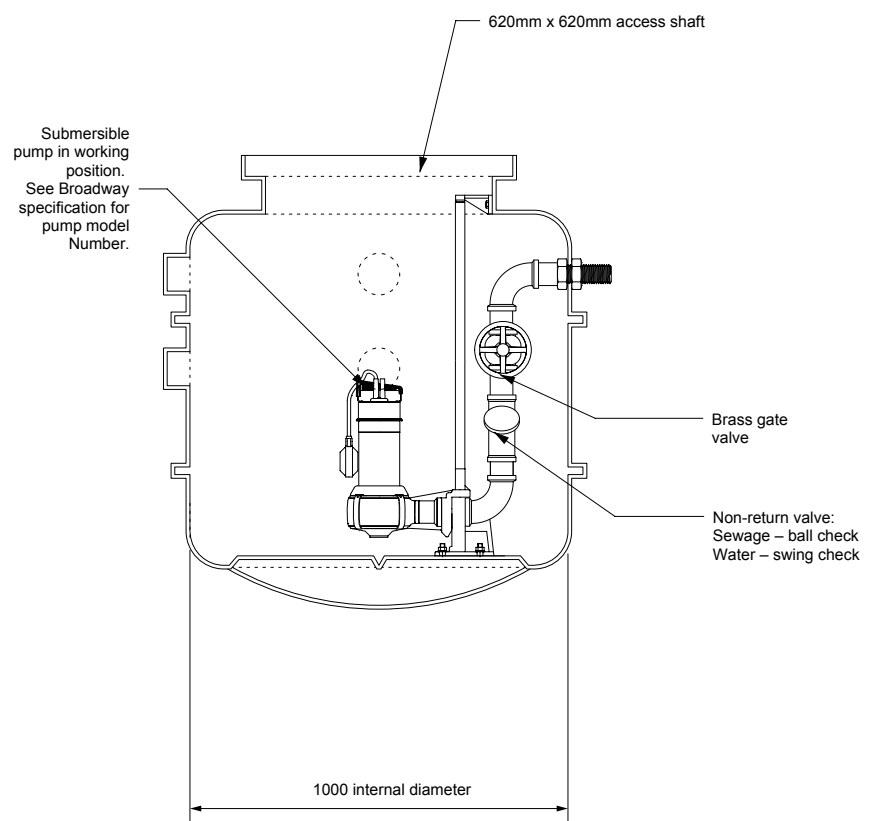

SECTIONAL ELEVATION

IMPORTANT: The tank must be surrounded in concrete as per installation procedures. Refer to 'Installation Detail' sheet available from the Broadway Group.

DIMENSIONS ARE SUBJECT TO DIMENSIONAL TOLERANCES. If critical, check physically prior to installation. This drawing is confidential and must not be copied, reproduced or passed to a third party without written permission from Broadway.

Rev.	Amendment	By	Chk'd	Date

Title **Vortech™ T1-120-1P-50GR pump station fitted with single pump (guide rail mounted), integral valves & DN50 pipework**

The Broadway Group

136 Stanwell Road, Ashford, Middlesex TW15 3QP. Telephone 0845 601 9006

Drawn **G.J.**
 Checked **T.E.**
 Date **Oct. 2005**
 Scale **1:20**

Internal reference

Drawing number **3149**

Revision

Client

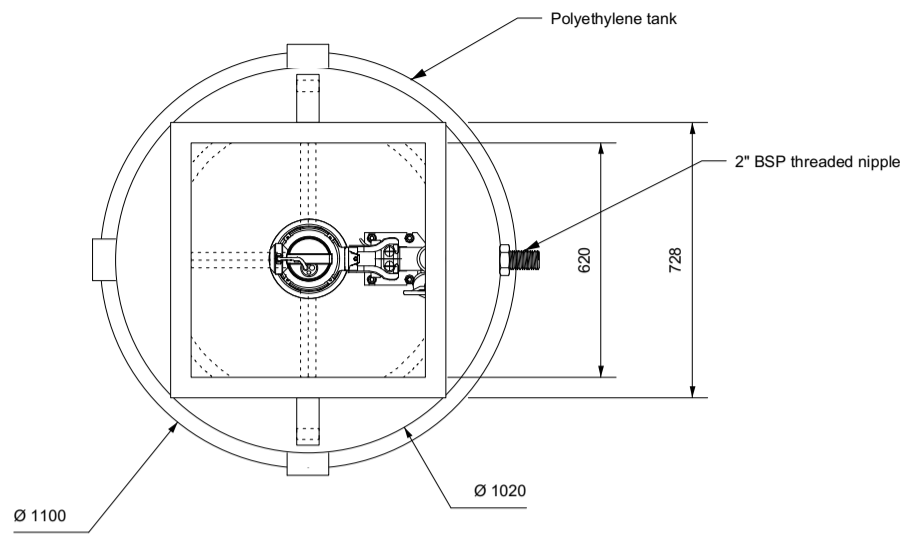

PLAN

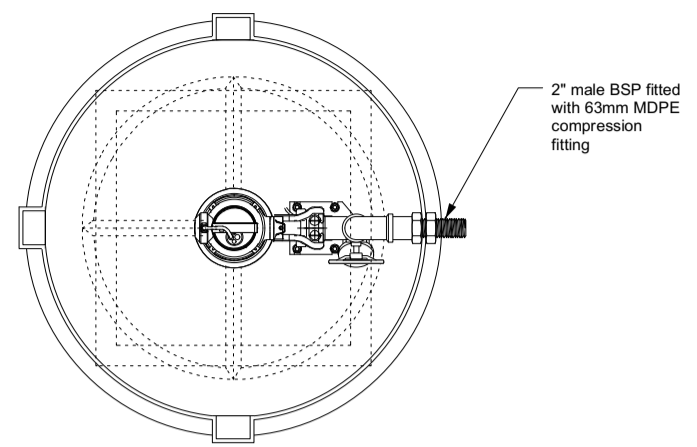

SECTIONAL PLAN

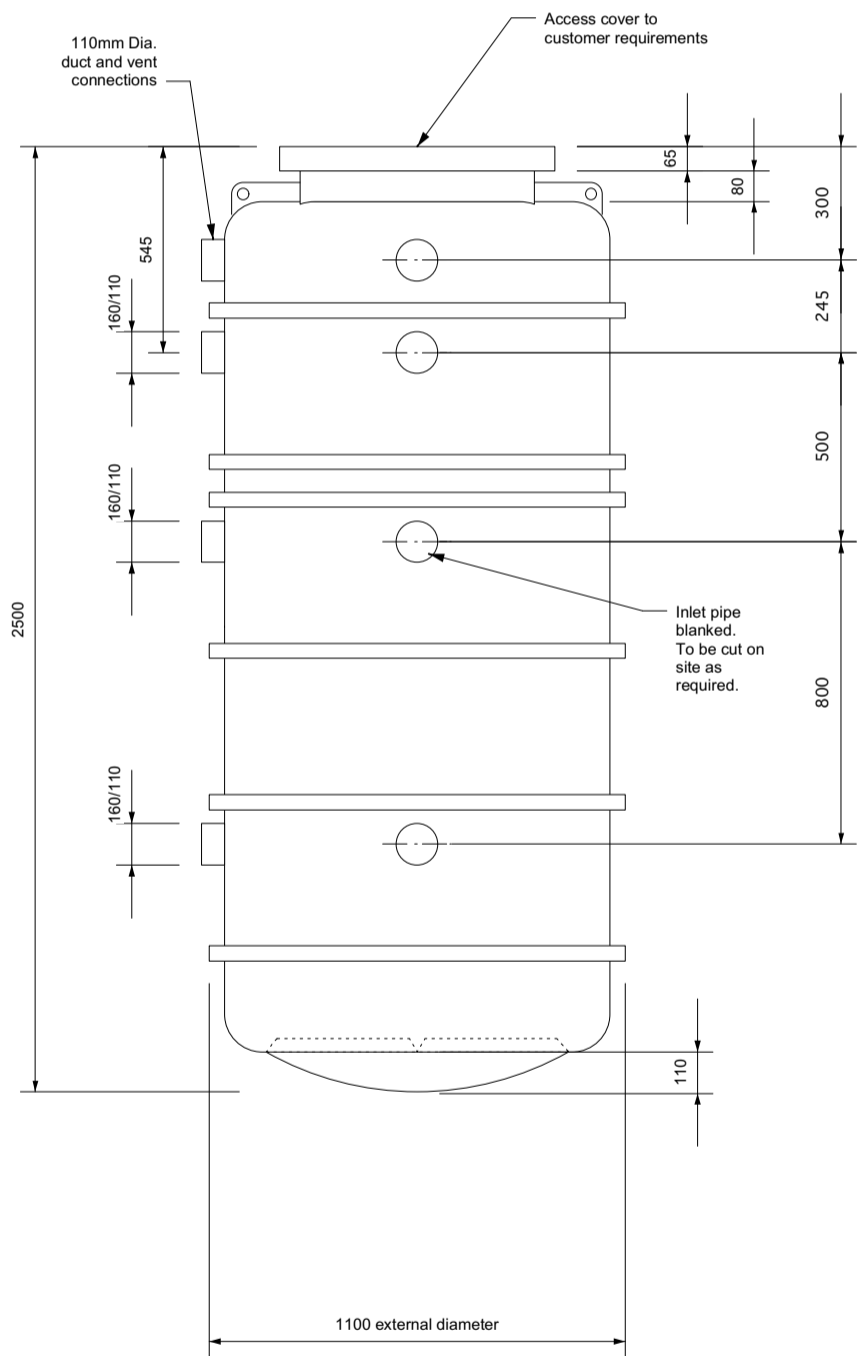

END ELEVATION

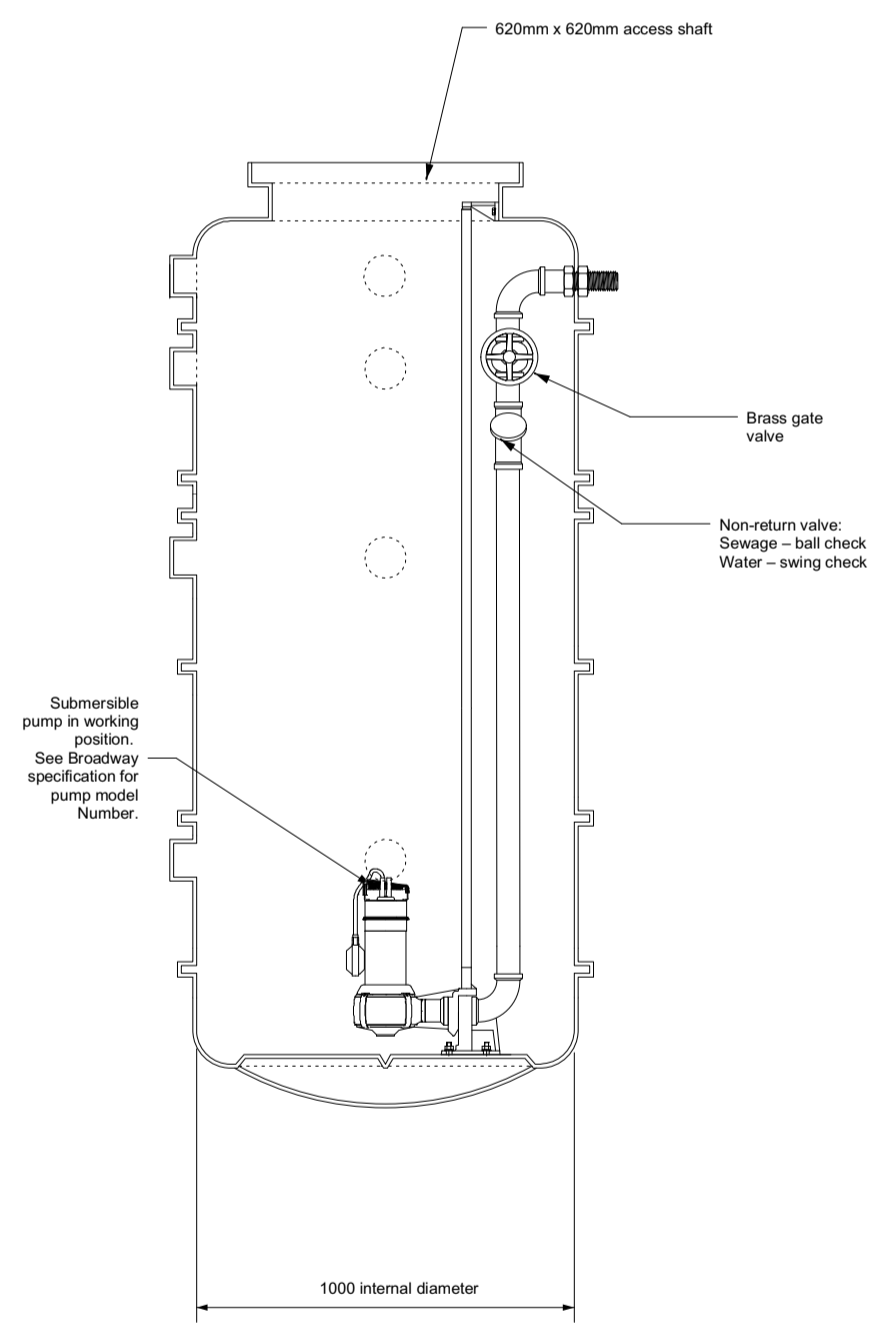

SECTIONAL ELEVATION

IMPORTANT: The tank must be surrounded in concrete as per installation procedures. Refer to 'Installation Detail' sheet available from the Broadway Group.

DIMENSIONS ARE SUBJECT TO DIMENSIONAL TOLERANCES. If critical, check physically prior to installation. This drawing is confidential and must not be copied, reproduced or passed to a third party without written permission from Broadway.

Rev.	Amendment	By	Chk'd	Date

Client	Title Vortech™ T1-250-1P-50GR pump station fitted with single pump (guide rail mounted), integral valves & DN50 pipework The Broadway Group Sutton Court Farm, Sutton Lane, Langley, Berks, SL3 8AR. England Telephone 0845 601 9006	Drawn G.J.	Internal reference		
		Checked T.E.			
		Date Oct. 2007	Drawing number	3160	Revision
		Scale 1:20			

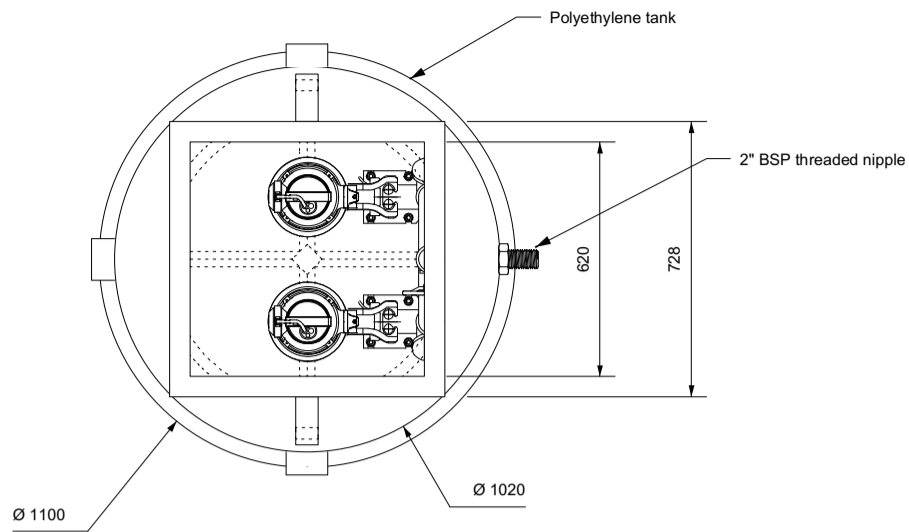

PLAN

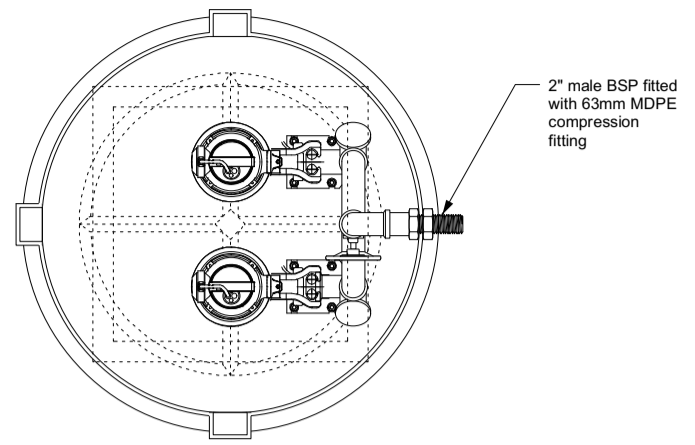

SECTIONAL PLAN

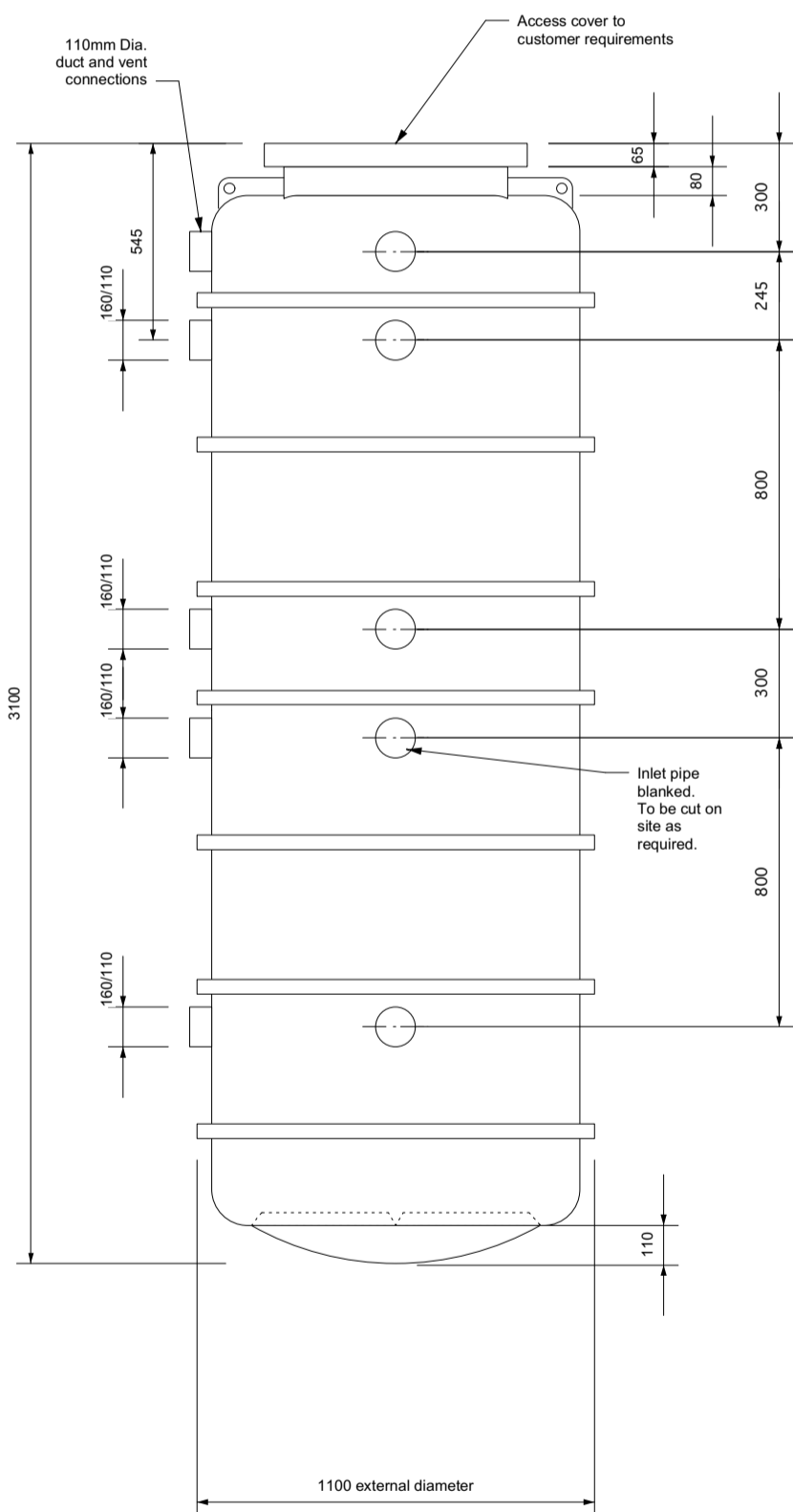

END ELEVATION

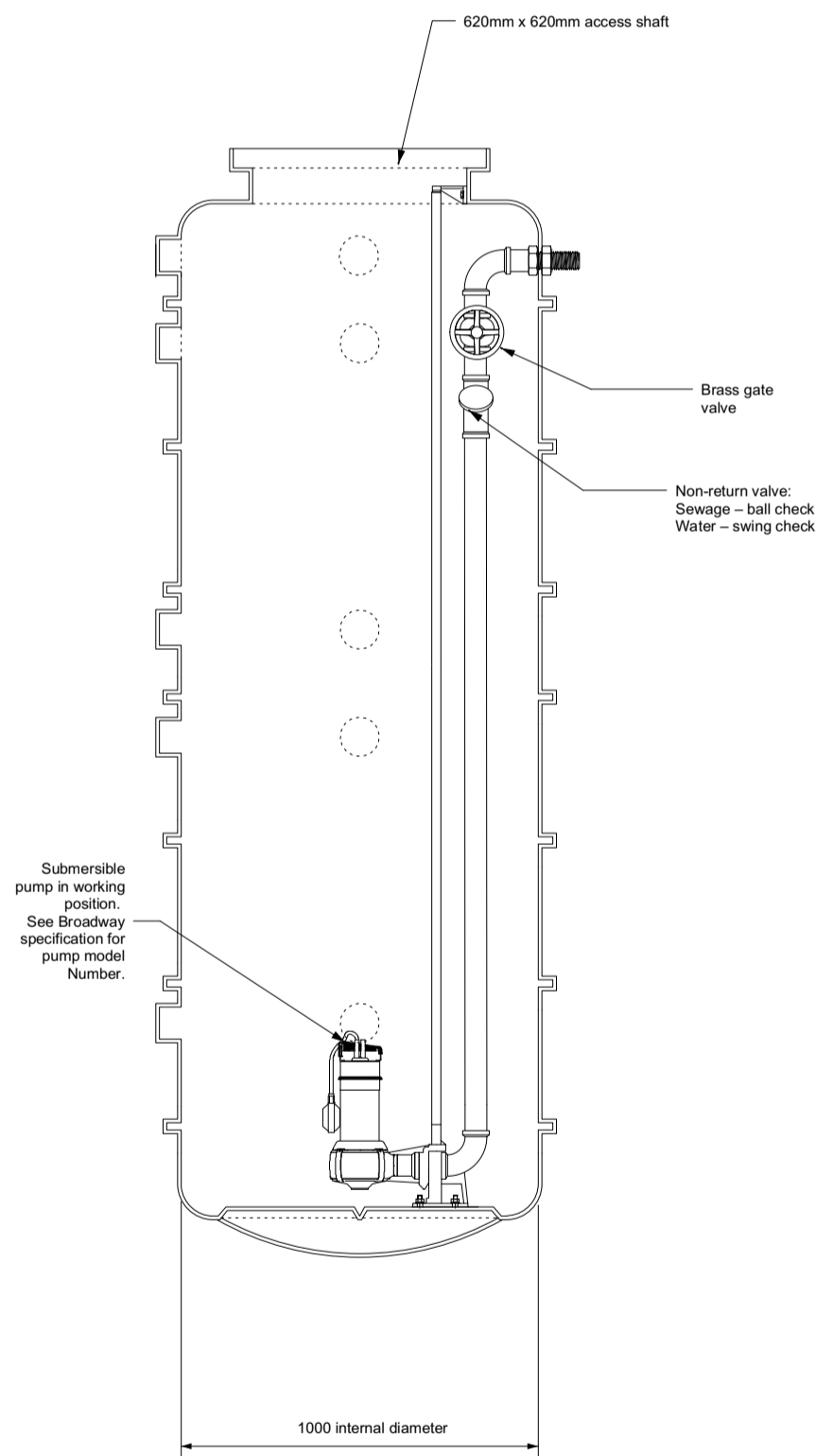

SECTIONAL ELEVATION

IMPORTANT: The tank must be surrounded in concrete as per installation procedures. Refer to 'Installation Detail' sheet available from the Broadway Group.

DIMENSIONS ARE SUBJECT TO DIMENSIONAL TOLERANCES. If critical, check physically prior to installation. This drawing is confidential and must not be copied, reproduced or passed to a third party without written permission from Broadway.

Rev.	Amendment	By	Chk'd	Date

Title **Vortech™ T1-300-2P-50GR pump station fitted with twin pumps (guide rail mounted), integral valves & DN50 pipework**

The Broadway Group
Sutton Court Farm, Sutton Lane,
Langley, Berks, SL3 8AR. England
Telephone 0845 601 9006

Drawn G.J.
Checked T.E.
Date Oct. 2007
Scale 1:20

Internal reference
Drawing number 3163
Revision

Client

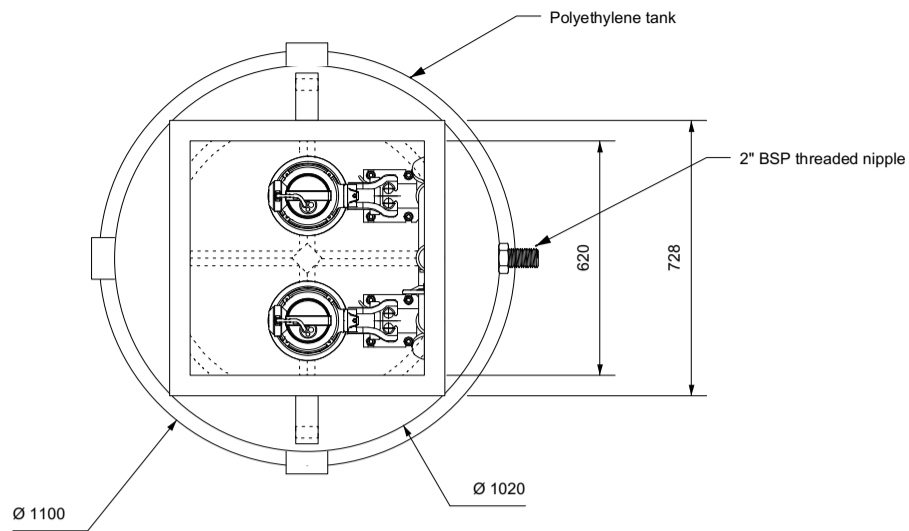

PLAN

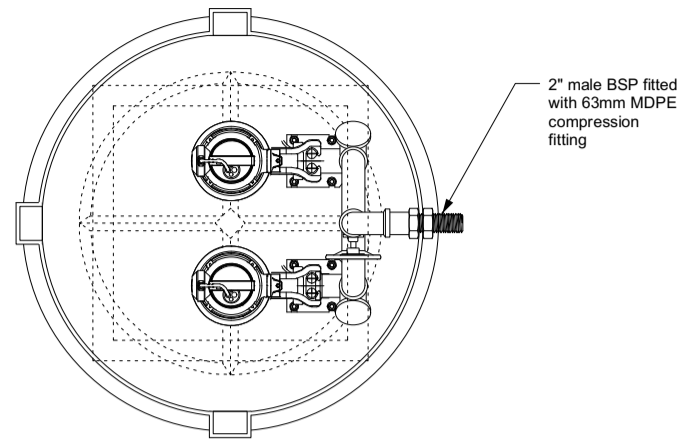

SECTIONAL PLAN

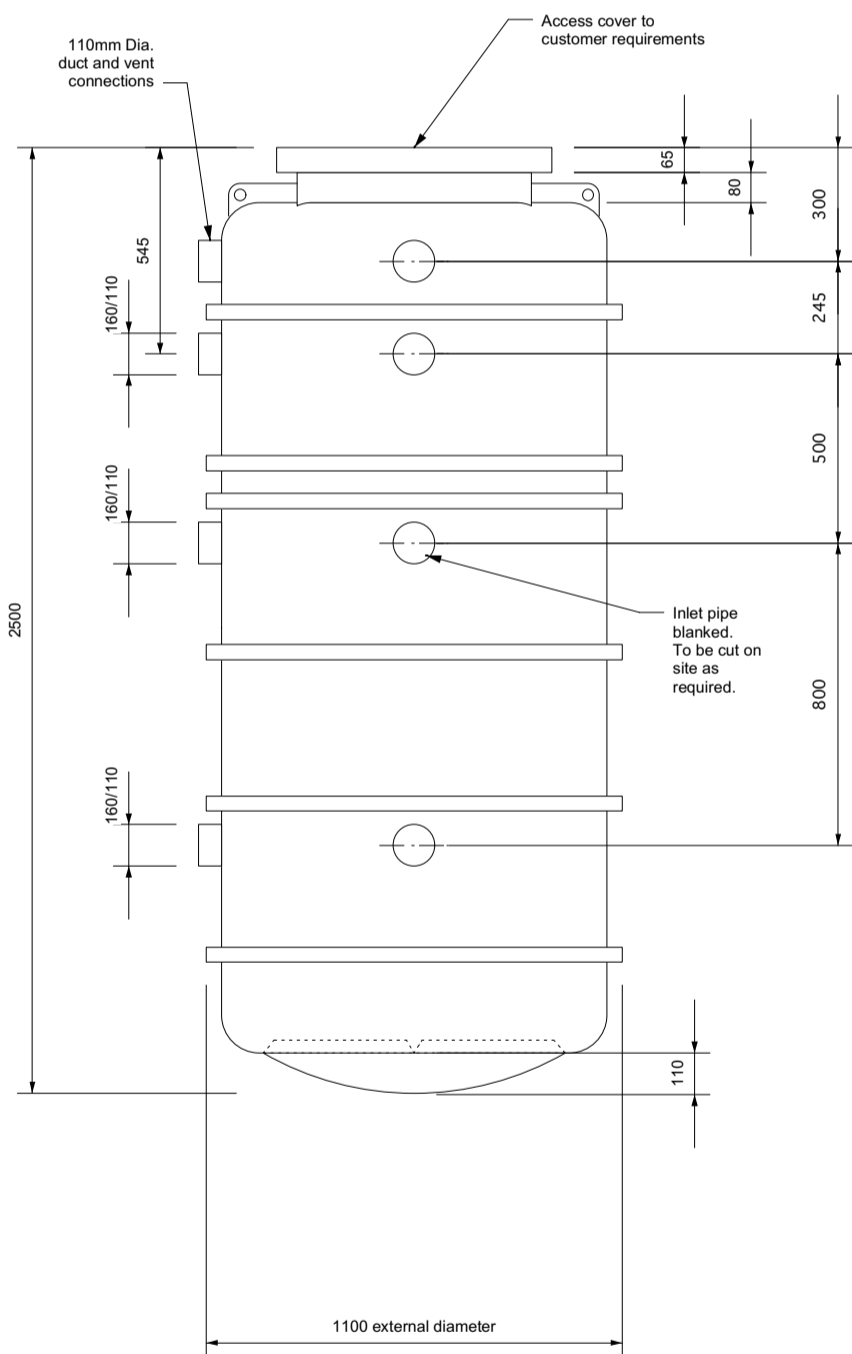

END ELEVATION

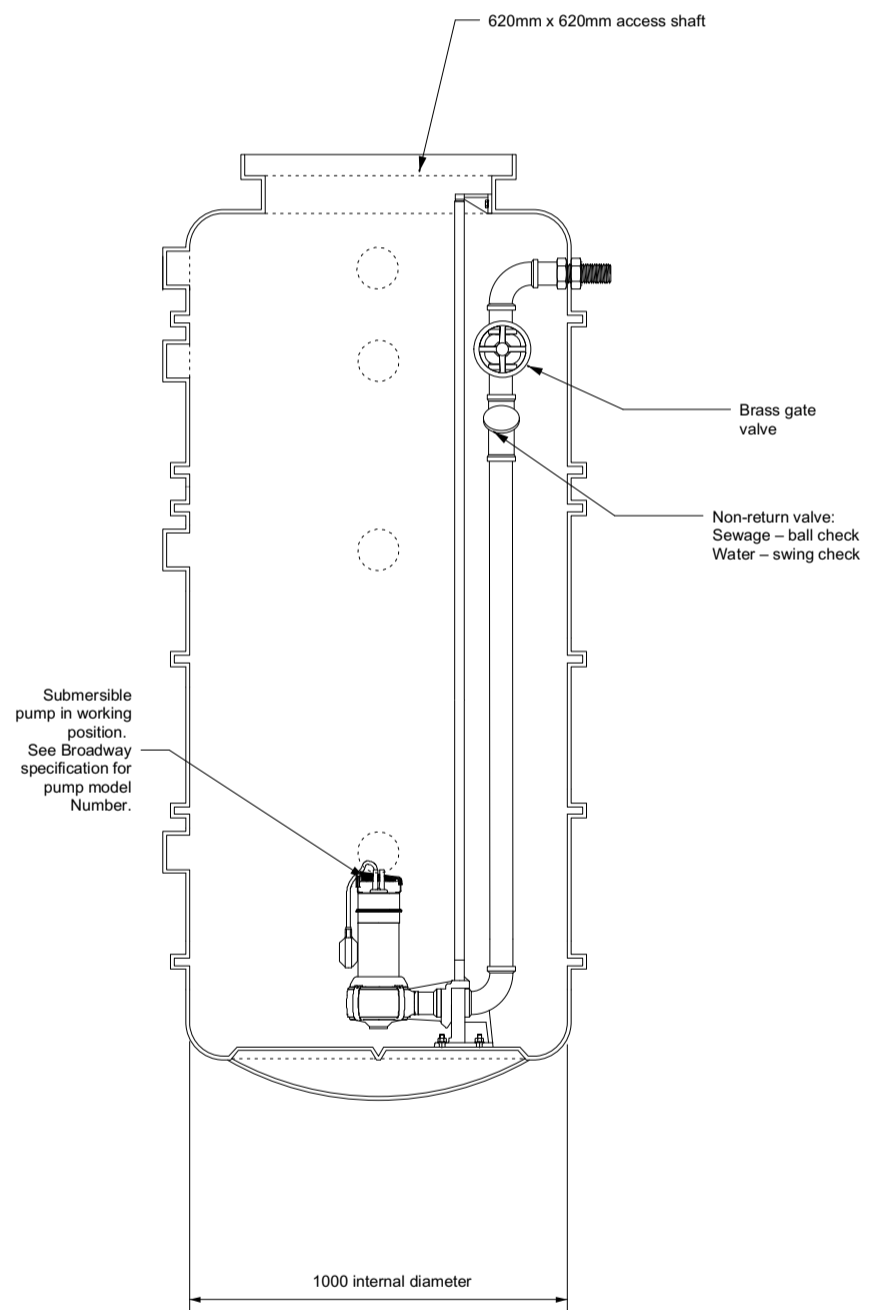

SECTIONAL ELEVATION

IMPORTANT: The tank must be surrounded in concrete as per installation procedures. Refer to 'Installation Detail' sheet available from the Broadway Group.

DIMENSIONS ARE SUBJECT TO DIMENSIONAL TOLERANCES. If critical, check physically prior to installation. This drawing is confidential and must not be copied, reproduced or passed to a third party without written permission from Broadway.

Rev.	Amendment	By	Chk'd	Date

Title Vortech™ T1-250-2P-50GR pump station fitted with twin pumps (guide rail mounted), integral valves & DN50 pipework	Client	The Broadway Group Sutton Court Farm, Sutton Lane, Langley, Berks, SL3 8AR. England Telephone 0845 601 9006	Drawn G.J.	Internal reference
			Checked T.E.	
			Date Oct. 2007	Drawing number 3161
			Scale 1:20	

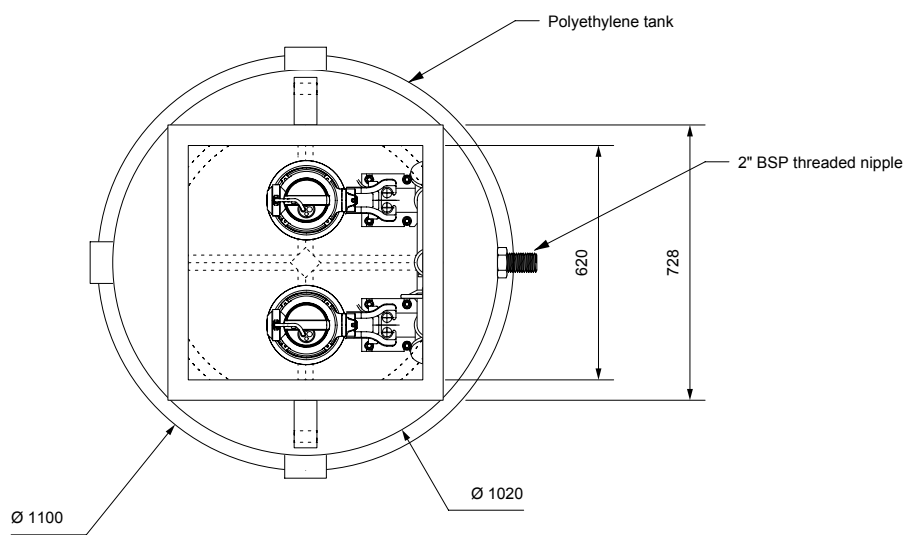

PLAN

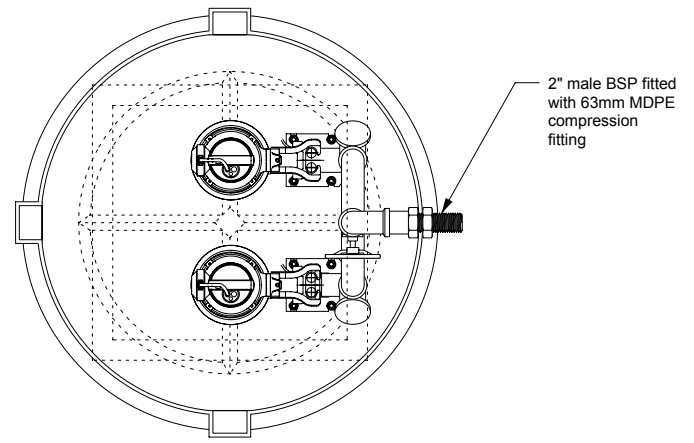

SECTIONAL PLAN

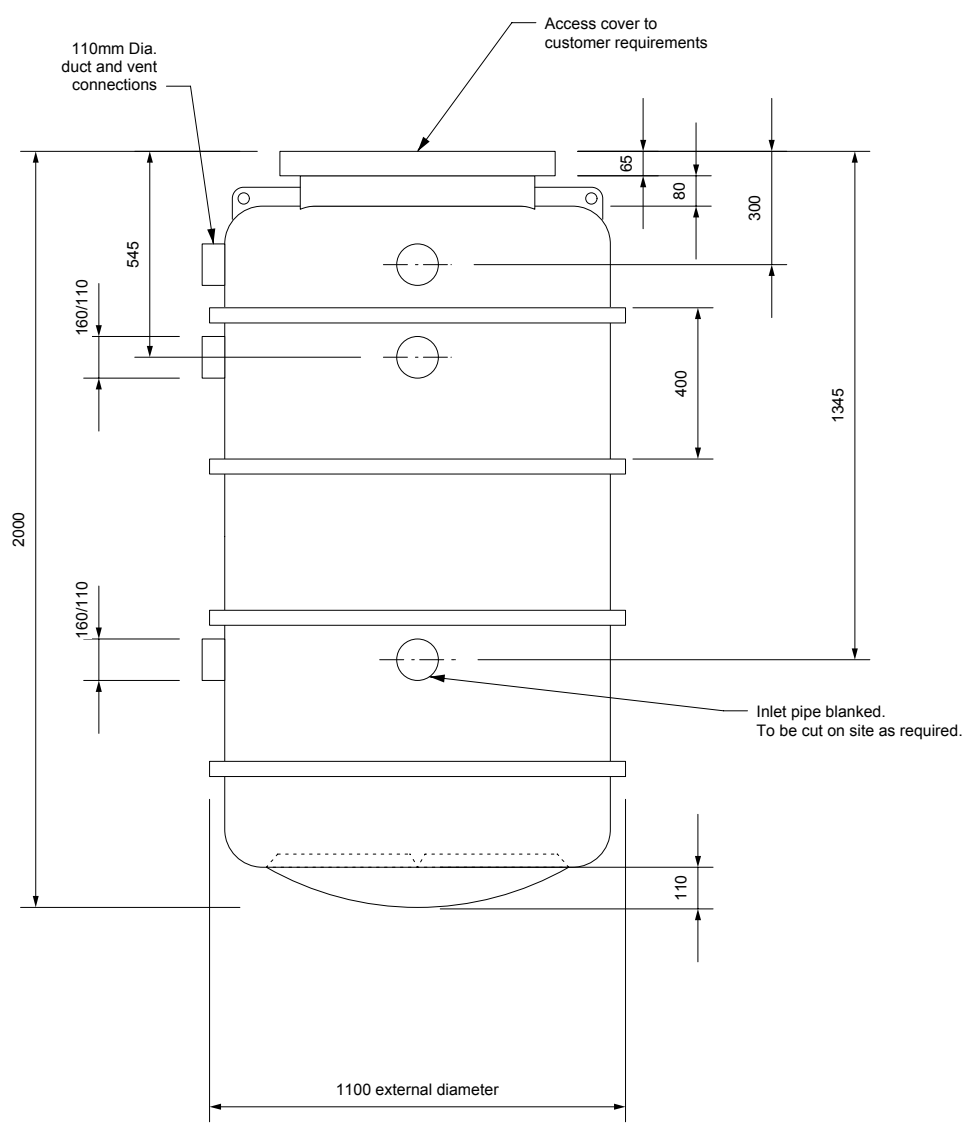

END ELEVATION

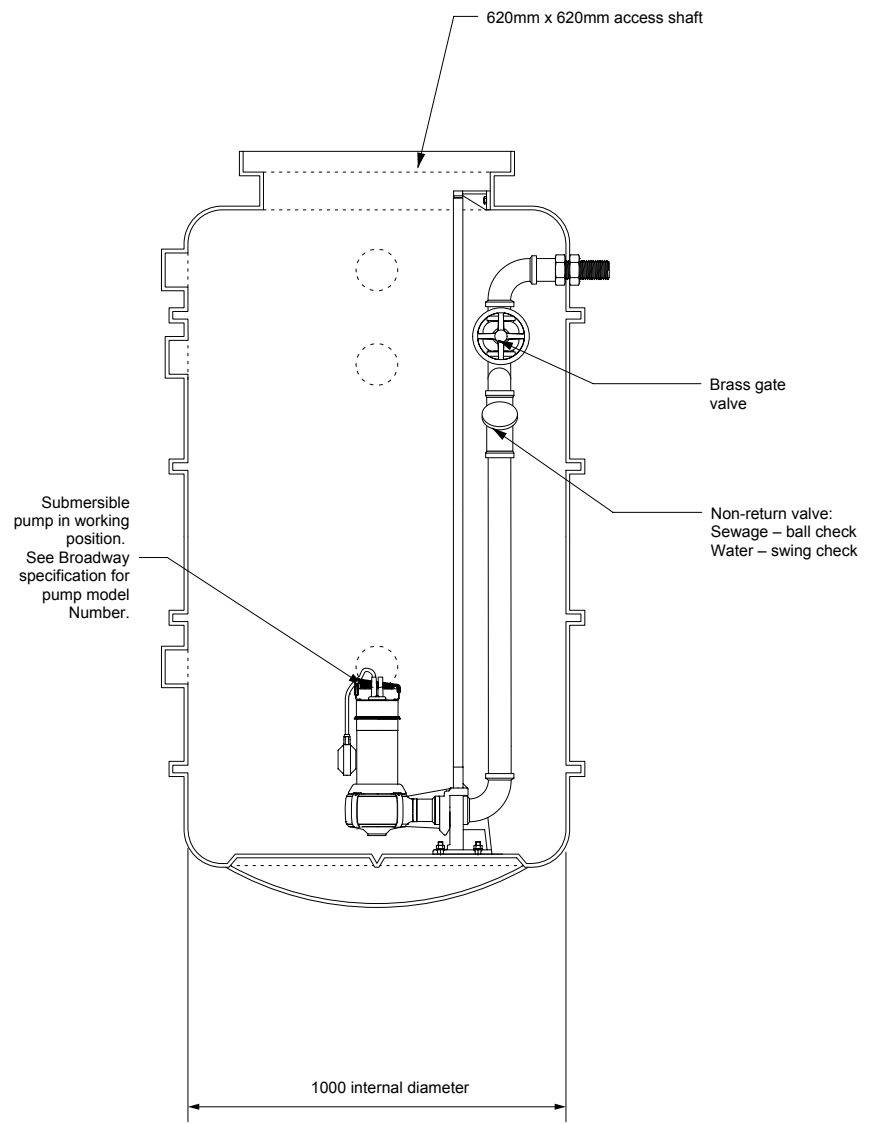

SECTIONAL ELEVATION

IMPORTANT: The tank must be surrounded in concrete as per installation procedures. Refer to 'Installation Detail' sheet available from the Broadway Group.

DIMENSIONS ARE SUBJECT TO DIMENSIONAL TOLERANCES. If critical, check physically prior to installation. This drawing is confidential and must not be copied, reproduced or passed to a third party without written permission from Broadway.

Rev.	Amendment	By	Chk'd	Date

Title **Vortech™ T1-200-2P-50GR pump station fitted with single pump (guide rail mounted), integral valves & DN50 pipework**

The Broadway Group
136 Stanwell Road, Ashford, Middlesex
TW15 3QP. Telephone 0845 601 9006

Drawn **G.J.**
Checked **T.E.**
Date **Oct. 2005**
Scale **1:20**

Internal reference
Drawing number **3159**
Revision

Client

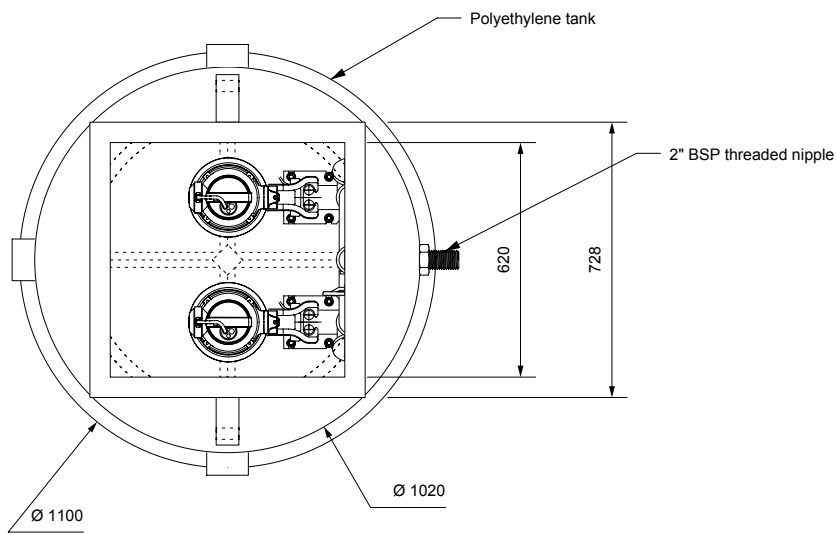

PLAN

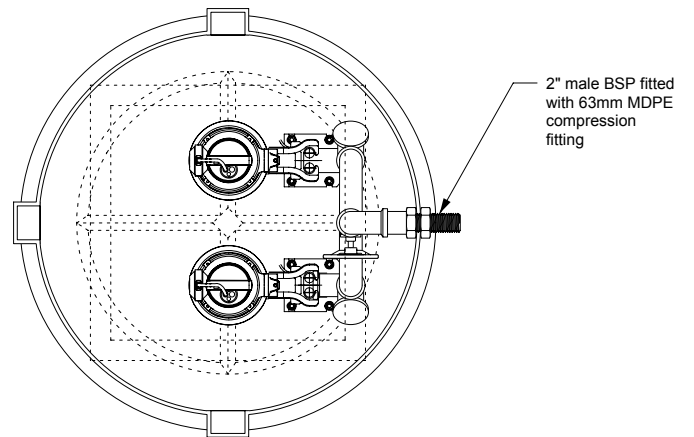

SECTIONAL PLAN

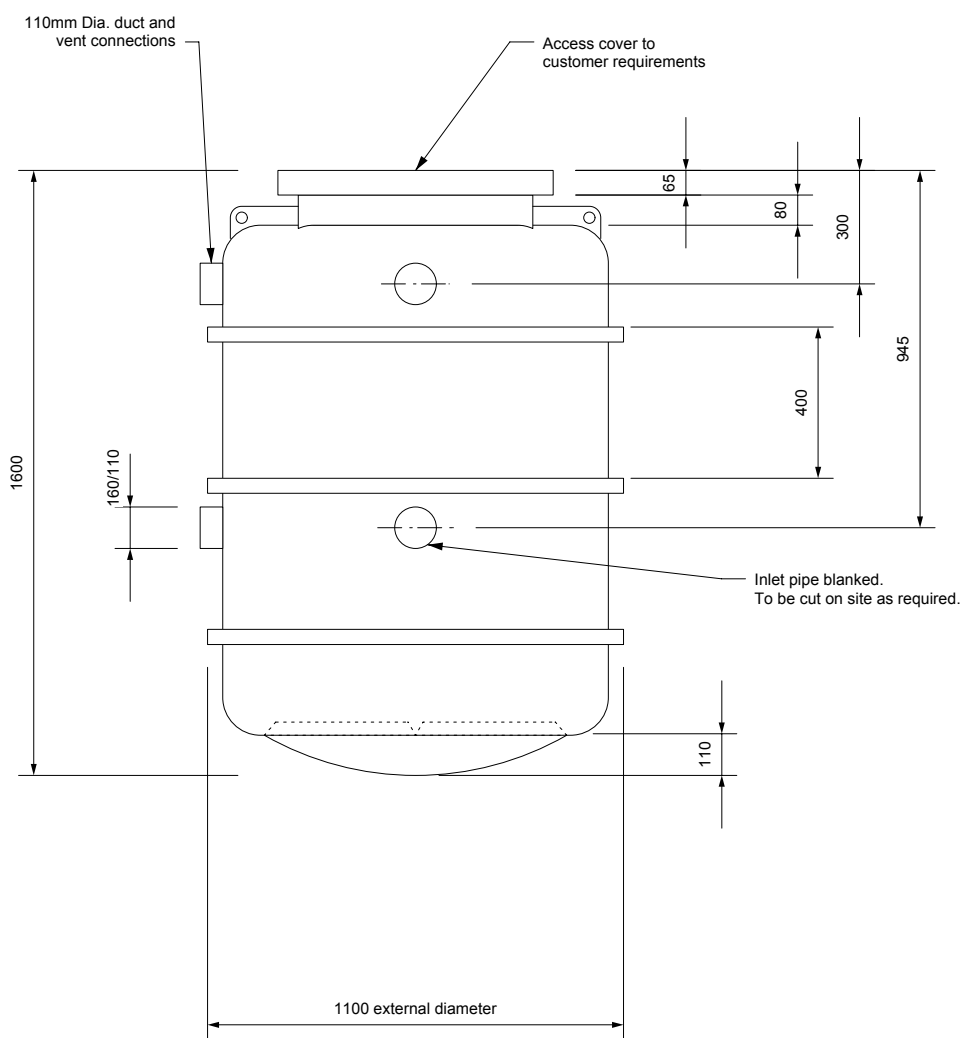

END ELEVATION

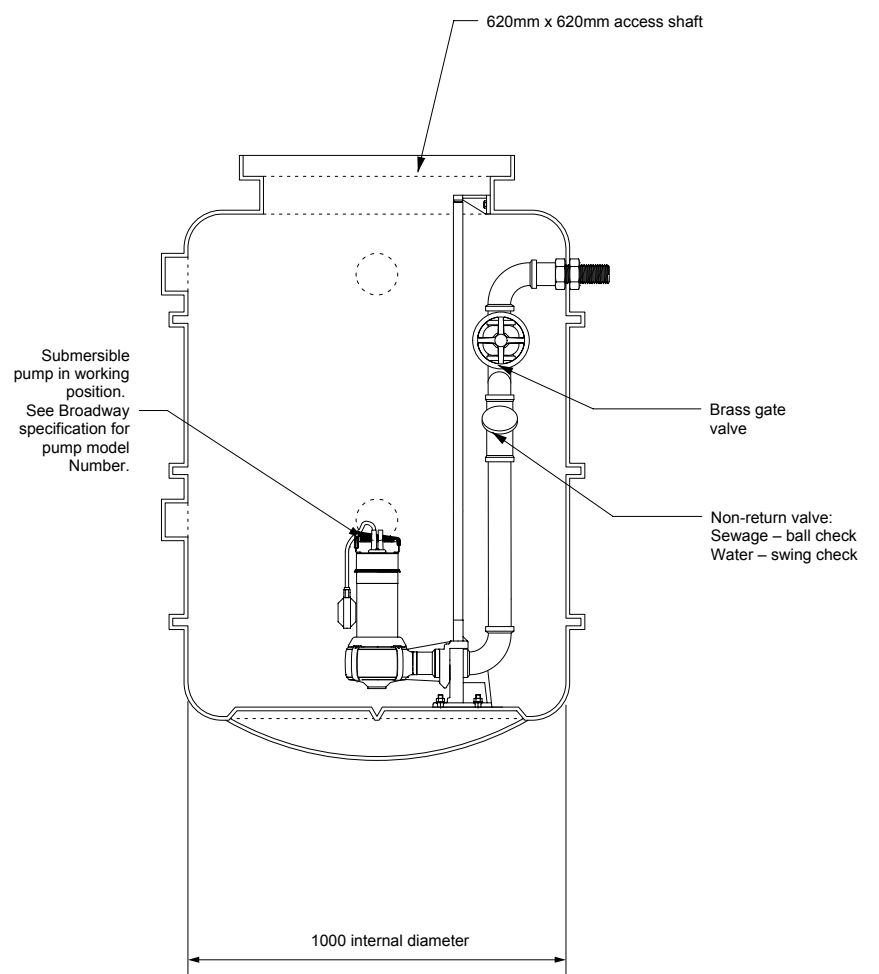

SECTIONAL ELEVATION

IMPORTANT: The tank must be surrounded in concrete as per installation procedures. Refer to 'Installation Detail' sheet available from the Broadway Group.

DIMENSIONS ARE SUBJECT TO DIMENSIONAL TOLERANCES. If critical, check physically prior to installation. This drawing is confidential and must not be copied, reproduced or passed to a third party without written permission from Broadway.

Rev.	Amendment	By	Chk'd	Date
------	-----------	----	-------	------

Title **Vortech™ T1-160-2P-50GR pump station fitted with single pump (guide rail mounted), integral valves & DN50 pipework**

The Broadway Group

136 Stanwell Road, Ashford, Middlesex TW15 3QP. Telephone 0845 601 9006

Drawn **G.J.**
 Checked **T.E.**
 Date **Oct. 2005**
 Scale **1:20**

Internal reference

Drawing number **3155**

Revision

Client

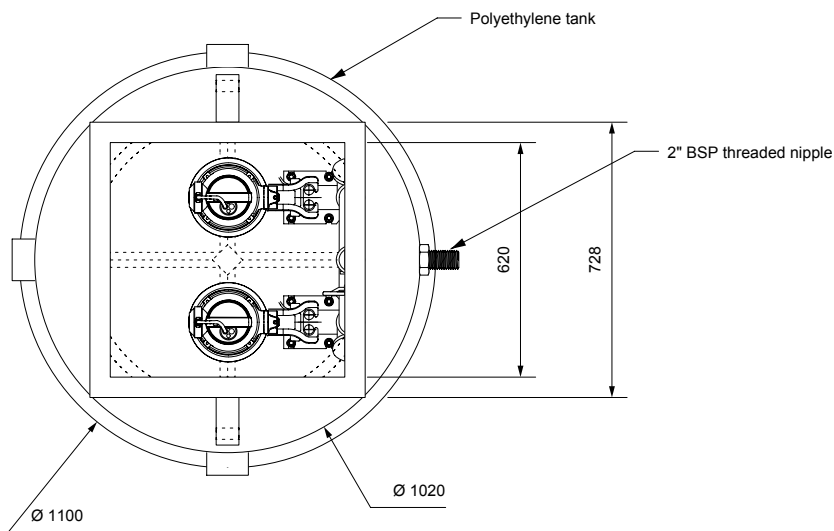

PLAN

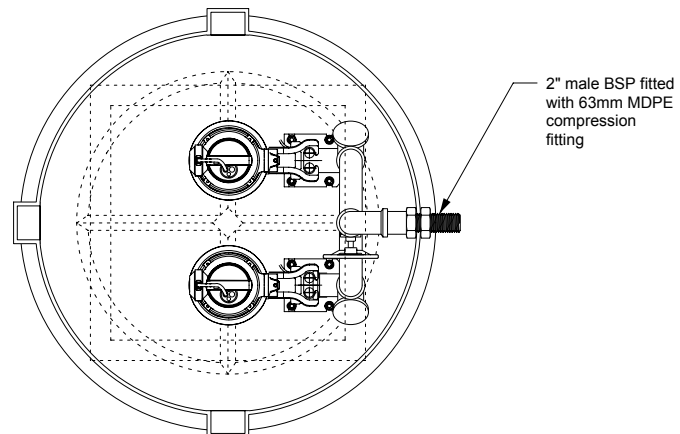

SECTIONAL PLAN

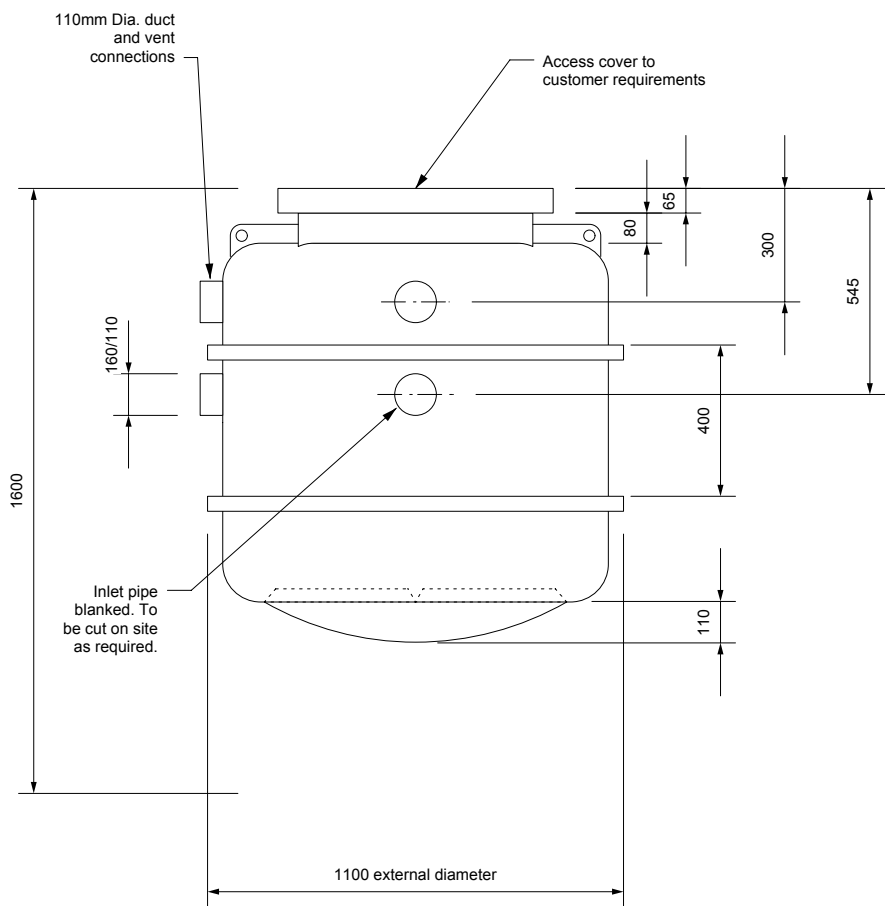

END ELEVATION

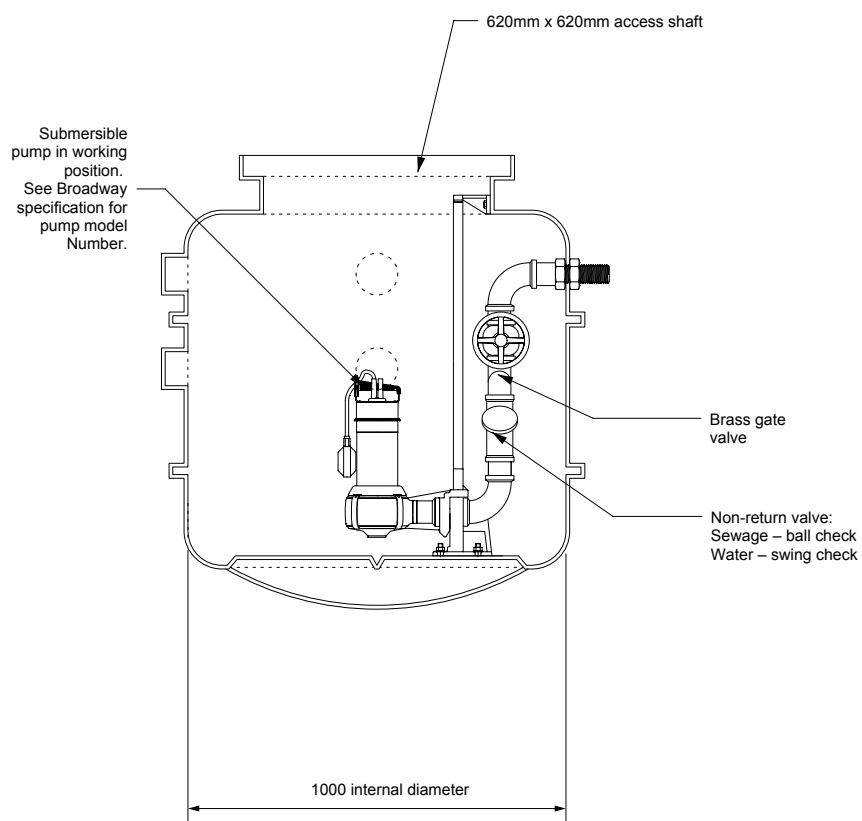

SECTIONAL ELEVATION

IMPORTANT: The tank must be surrounded in concrete as per installation procedures. Refer to 'Installation Detail' sheet available from the Broadway Group.

DIMENSIONS ARE SUBJECT TO DIMENSIONAL TOLERANCES. If critical, check physically prior to installation. This drawing is confidential and must not be copied, reproduced or passed to a third party without written permission from Broadway.

Rev.	Amendment	By	Chk'd	Date

Title **Vortech™ T1-120-2P-50GR pump station fitted with single pump (guide rail mounted), integral valves & DN50 pipework**

The Broadway Group

Drawn **G.J.**
 Checked **T.E.**
 Date **OCT. 2005**
 Scale **1:20**

Internal reference

Client

136 Stanwell Road, Ashford, Middlesex TW15 3QP. Telephone 0845 601 9006

Drawing number **3151**

Revision

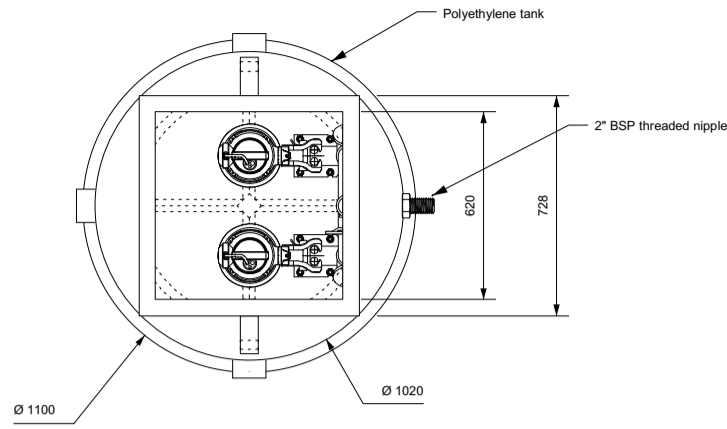

PLAN

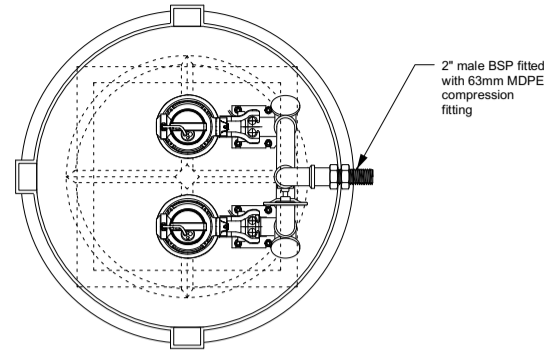

SECTIONAL PLAN

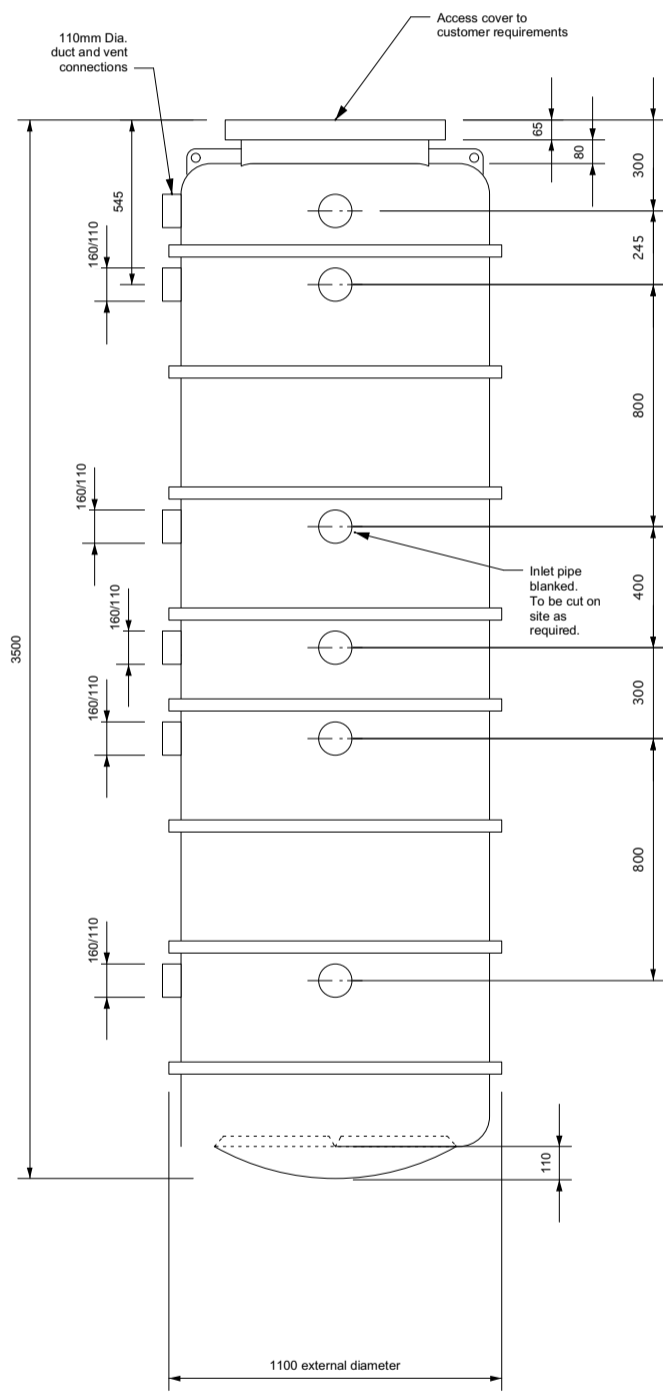

END ELEVATION

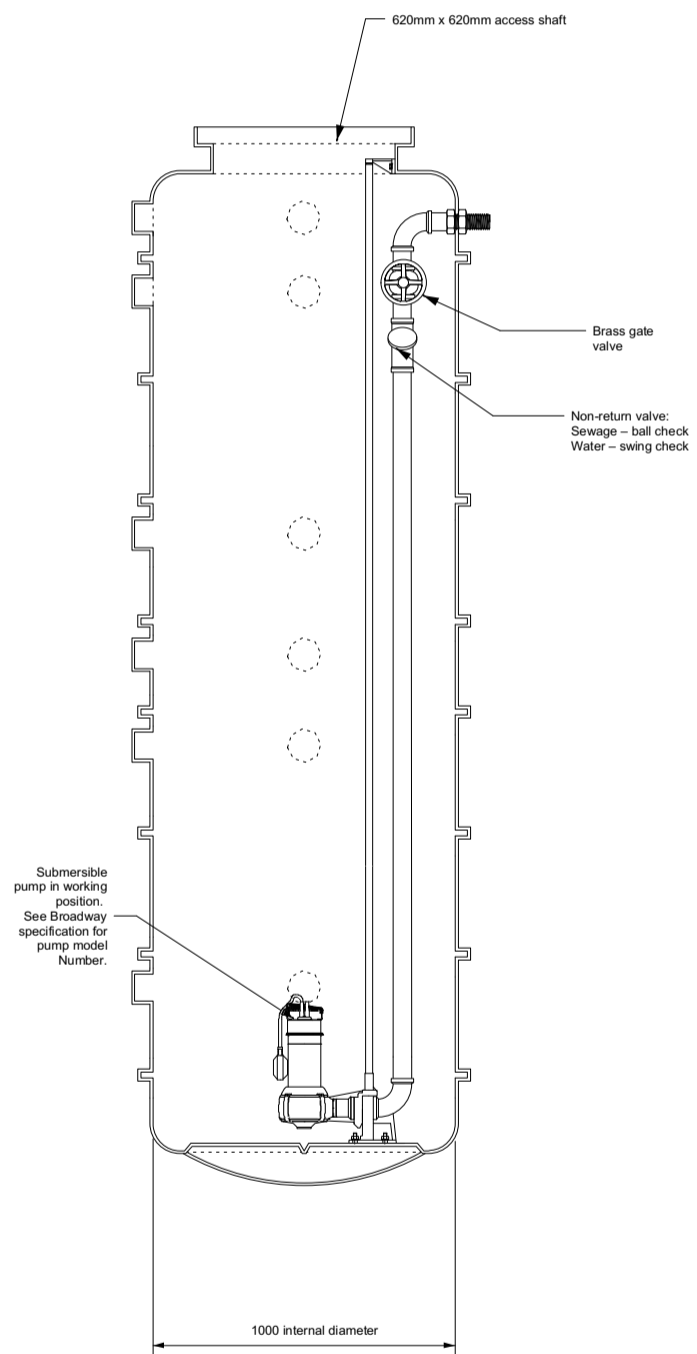

SECTIONAL ELEVATION

IMPORTANT: The tank must be surrounded in concrete as per installation procedures. Refer to 'Installation Detail' sheet available from the Broadway Group.

DIMENSIONS ARE SUBJECT TO DIMENSIONAL TOLERANCES. If critical, check physically prior to installation. This drawing is confidential and must not be copied, reproduced or passed to a third party without written permission from Broadway.

Rev.	Amendment	By	Chk'd	Date

Title Vortech™ T1-350-2P-50GR pump station fitted with twin pumps (guide rail mounted), integral valves & DN50 pipework	The Broadway Group Sutton Court Farm, Sutton Lane, Langley, Berks, SL3 8AR. England Telephone 0845 601 9006	Drawn G.J.	Internal reference	
		Checked T.E.		
Client		Date Oct. 2007	Drawing number 3165	Revision
		Scale 1:25		